

GE
Security
Fire & Life Safety

Remote Booster Power Supply Technical Reference Manual

P/N 3100485 • REV 3.0 • ISS 06JUL07



Copyright Copyright © 2007 GE Security, Inc. All rights reserved.

This document may not be copied in whole or in part or otherwise reproduced without prior written consent from GE Security, Inc., except where specifically permitted under U.S. and international copyright law.

Document number: 3100485 Revision: 3.0

Disclaimer The information in this document is subject to change without notice. GE Security, Inc. ("GE Security") assumes no responsibility for inaccuracies or omissions and specifically disclaims any liabilities, losses, or risks, personal or otherwise, incurred as a consequence, directly or indirectly, of the use or application of any of the contents of this document. For the latest documentation, contact your local supplier or visit us online at www.gesecurity.com.

This publication may contain examples of screen captures and reports used in daily operations. Examples may include fictitious names of individuals and companies. Any similarity to names and addresses of actual businesses or persons is entirely coincidental.

Trademarks and patents GE and the GE monogram are registered trademarks of General Electric Company. The Remote Booster Power Supply name and logo are registered trademarks of GE Security.

Other trade names used in this document may be trademarks or registered trademarks of the manufacturers or vendors of the respective products.

Intended use Use this product only for the purpose it was designed for; refer to the data sheet and user documentation for details. For the latest product information, contact your local supplier or visit us online at www.gesecurity.com.

FCC compliance This equipment has been tested and found to comply with the limits for a Class A digital device, pursuant to part 15 of the FCC Rules. These limits are designed to provide reasonable protection against harmful interference when the equipment is operated in a commercial environment. This equipment generates, uses, and can radiate radio frequency energy and, if not installed and used in accordance with the instruction manual, may cause harmful interference to radio communications.

You are cautioned that any changes or modifications not expressly approved by the party responsible for compliance could void the user's authority to operate the equipment.

European Union directives The European directive "Waste Electrical and Electronic Equipment" (WEEE) aims to minimize the impact of electrical and electronic equipment waste on the environment and human health. For proper treatment, recovery, and recycling, you can return the equipment marked with this symbol to your local supplier upon the purchase of equivalent new equipment, or dispose of it in designated collection points. Further information can be found on the following website: www.recyclethis.info.



European representative for manufacture (EMC): GE Security B.V., Kelvinstraat 7, 6003 DH Weert, The Netherlands.

Content

Important information • iii

- Limitation of liability • iii
- Remote Booster Power Supply FCC compliance • iii

Introduction • 4

- Models covered • 4
- Compatibility • 4

Installation procedure checklist • 5

Getting started • 6

- Description • 6
- Component descriptions • 6
- Specifications • 7
- LED indicators • 8

Installing the enclosure • 10

- Enclosure dimensions • 10

Installing option modules in the enclosure • 11

Installing the circuit board in the enclosure • 13

Setting the jumpers • 14

- NAC Class A or Class B (JP1 and JP2) • 14
- Ground fault enable (JP3) • 14
- Battery charging (JP4) • 15

Setting the DIP switches • 16

- Sense 1 and 2 operation (SW1-1 to 3) • 16
- Synchronization control (SW1-4) • 17
- NAC circuit operation (SW1-5 to 8 and SW2-1 to 4) • 18
- Genesis mode for continuous NACs (SW2-5) • 19
- AC power loss reporting (SW2-6) • 19
- Auxiliary control during AC power loss (SW2-7) • 20
- Class A or B NAC configuration (SW2-8) • 20

Wire routing • 21

Connecting the field wiring • 22

- AC power wiring • 22
- Battery wiring • 22
- NAC Class B (Style Y) wiring • 23
- NAC Class A (Style Z) wiring • 23
- AUX power wiring • 24
- Common trouble relay wiring • 25
- Sense circuit wiring • 25
- Tests for grounds, opens, and shorts • 26

NAC wiring using CC1(S) modules • 27

- Single CC1(S) using the BPS's 200 mA AUX Continuous circuit • 27
- Multiple CC1(S) modules using the BPS's sense inputs • 28
- Multiple CC1(S) modules using one of the BPS's NAC/AUX circuits • 29

Installing the 3-TAMP tamper switch • 30

Battery calculation worksheet • 31

Notification appliance circuit calculations • 33

- Introduction • 33
- What you'll need • 33
- Worksheet method • 35
- Equation method • 36

Understanding BPS synchronization • 39

- Connection of booster power supplies • 39
- Synchronization of visible outputs • 40
- Synchronization of visible and audible outputs • 40

Applications • 42

Key • 42

Genesis circuit notification • 43

Conventional visible and audible circuit notification • 44

Conventional visible and audible circuit to Genesis notification • 45

Conventional audible or visible circuit to Genesis notification • 45

Genesis visible circuit and conventional audible circuit to Genesis notification • 46

Conventional split mode circuit with fault tolerance notification • 47

Genesis split mode circuit with fault tolerance notification • 48

CDR-3 Coder to Genesis notification • 48

CDR-3 Coder to conventional notification • 49

CDR-3 Coder to Genesis visibles and conventional audibles • 50

Security • 50

Access control power supply • 51

Important information

Limitation of liability

This product has been designed to meet the requirements of NFPA 72 *National Fire Alarm Code*, UL 864 *Standard for Control Units for Fire Protective Signaling Systems*, and ULC S527 *Standard for Control Units for Fire Alarm Systems*. Installation in accordance with this manual, applicable codes, and the instructions of the authority having jurisdiction is mandatory. GE Security shall not under any circumstances be liable for any incidental or consequential damages arising from loss of property or other damages or losses owing to the failure of GE Security products beyond the cost of repair or replacement of any defective products. GE Security reserves the right to make product improvements and change product specifications at any time.

While every precaution has been taken during the preparation of this manual to ensure the accuracy of its contents, GE Security assumes no responsibility for errors or omissions.

Remote Booster Power Supply FCC compliance

This equipment can generate and radiate radio frequency energy. If the equipment is not installed in accordance with this manual, it may cause interference to radio communications. This equipment has been tested and found to comply with the limits for Class A computing devices pursuant to Subpart B of Part 15 of the FCC Rules. These rules are designed to provide reasonable protection against such interference when this equipment is operated in a commercial environment. Operation of this equipment is likely to cause interference, in which case the user, at his own expense, will be required to take whatever measures may be required to correct the interference.

Introduction

This installation manual is intended for use by installers and field technicians. It provides the installation procedures, wiring diagrams, DIP switch settings, etc. required to install and set up the Remote Booster Power Supply (BPS).

Models covered

The following table lists the booster power supply models that are covered in this manual.

Catalog number	Description
BPS6A	6.5 A booster power supply
BPS6A/230	6.5 A booster power supply
BPS6AC	6.5 A booster power supply
BPS6CAA	6.5 A booster power supply
MIRBPS6A	6.5 A booster power supply
MIRBPS6A/230	6.5 A booster power supply
XLS-BPS6A	6.5 A booster power supply
XLS-BPS6A/230	6.5 A booster power supply
EBPS6A	6.5 A booster power supply
EBPS6A/230	6.5 A booster power supply
BPS10A	10 A booster power supply
BPS10A/230	10 A booster power supply
BPS10AC	10 A booster power supply
BPS10CAA	10 A booster power supply
MIRBPS10A	10 A booster power supply
MIRBPS10A/230	10 A booster power supply
XLS-BPS10A	10 A booster power supply
XLS-BPS10A/230	10 A booster power supply
EBPS10A	10 A booster power supply
EBPS10A/230	10 A booster power supply

Compatibility

The input circuits of the booster power supply can be connected to 12 VDC or 24 VDC systems.

For details about device compatibility, refer to the *Remote Booster Power Supply ULI and ULC Compatibility List* (P/N 3100656).

Installation procedure checklist

Follow these steps to install and set up the booster power supply (BPS).

- Unpack the equipment**
- Review the “Getting started” section**
- Review the applications:** Review the applications to determine how you want to use the BPS. See the “Applications” section.
- Prepare the site:** Make sure the installation location is free from construction dust and debris and extreme temperature ranges and humidity.
- Install the enclosure:** See “Installing the enclosure” for enclosure dimensions.
- Install option modules if required:** See “Installing option modules in the enclosure.”
- Set the jumpers:** See “Setting the jumpers.”
- Set the DIP switch options:** See “Setting the DIP switches.”
- Review wire routing:** See “Wire routing.”
- Connect the field wiring:** See “Connecting the field wiring.”
- Install the 3-TAMP tamper switch (if one is used): See “Installing the 3-TAMP tamper switch.”
- Test for proper operation**

WARNING: Make sure that the AC power circuit breaker is off before connecting wires to the terminal block.

Caution: Turn on AC power before connecting the batteries.

Getting started

Description

The 6.5 amp and 10 amp booster power supplies are designed to extend the signaling capacity of a fire alarm, security, or access control system. The BPSs can be connected to existing Class A or Class B notification appliance circuits (NACs) or activated via option modules. The BPSs can either pass or generate synchronization signals for Genesis sync strobes. The BPSs have four independent NAC/AUX circuits that are supervised when configured for NAC, plus a trouble relay.

Component descriptions

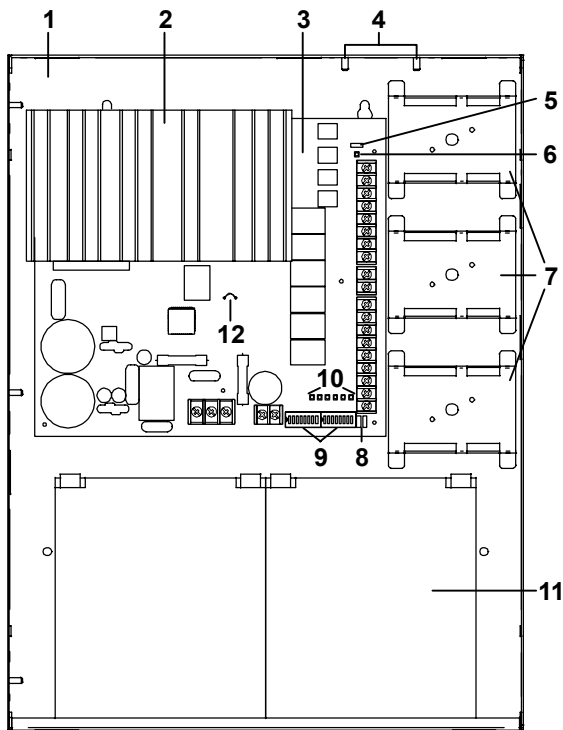

Component	Description
1	Enclosure: Houses the electronics and two standby batteries
2	Heat sink: Distributes heat away from the circuit board
3	Circuit board: Provides connections for all circuits
4	Tamper switch standoffs: 3-TAMP mounting standoffs
5	Jumper JP3: Ground fault enable or disable option
6	AC LED: AC power on

Component	Description
7	Mounting brackets: Option module mounting brackets
8	Jumpers JP1 and JP2: Class A or Class B NAC option
9	DIP switches: Two eight-position DIP switches used for configuration
10	Circuit LEDs: NAC, battery, and ground fault trouble LEDs
11	Batteries: Up to two 10 Ah batteries fit in the enclosure. For larger batteries, use an external battery cabinet (BC-1 or BC-2).
12	Jumper JP4: Battery charging jumper

Specifications

The following specifications apply to all BPS models.

AC line voltage	
6.5 amp BPS	120 VAC / 230 VAC (50/60 Hz) 390 watts
10 amp BPS	120 VAC / 230 VAC (50/60 Hz) 580 watts
Sense voltage (input)	6 to 45 VDC 11 to 33 VRMS (FWR and unfiltered DC)
Sense current (input)	6 mA @ 24 VDC, 3 mA @ 12 VDC, 12 mA @ 45 VDC
NAC output voltage (special application circuit)	17.93 to 26.40 VDC Note: All NACs are supervised.
Refer to the <i>Remote Booster Power Supply ULI and ULC Compatibility List</i> P/N 3100656 for the maximum number of devices that can be used on a NAC circuit.	
AUX output voltage (special application circuit)	19.0 to 26.48 VDC
NAC/AUX output current	3.0 A max. per circuit with 0.35 power factor (6.5 A or 10 A max. total for all NACs) (6.5 A or 8 A max. total for all AUXs)
NAC/AUX capacitive loading	10,000 μ F max. for continuous NAC circuits 2,200 μ F max. for stroking rate NAC circuits 2,200 μ F max. for AUX circuits
NAC/AUX class	Class B (Style Y) or Class A (Style Z)
Wire size	18 to 12 AWG (0.75 to 2.5 sq mm)
NAC EOL	UL: 15 k Ω (P/N EOL-15) ULC: Use P/N EOL-P1 and select the 15 k Ω resistor

Auxiliary output (continuous)	1 dedicated 200 mA auxiliary output, not supervised by BPS, included in total current Voltage range: 19.49 to 26.85
Common trouble relay	Form C, 1 A, 30 VDC (resistive)
Battery requirements [1]	6.5 to 24 Ah for fire and security applications (10 Ah max. in enclosure) -Under 10 Ah, cut JP4 -10 Ah or above, do not cut JP4
Battery charger current limit	1.2 A when the battery jumper wire is cut 2.1 A when the battery jumper wire is <i>not</i> cut
Operating environment	
Operating temperature	32 to 120 °F (0 to 49 °C)
Operating humidity	0 to 93% RH, noncondensing at 90 °F (32 °C)
Ground fault impedance	10 k Ω
Intended installation environment	Indoor-dry
[1] The maximum battery size the panel can charge is 24 Ah (Portalac PE12-23 or equivalent) for fire and security applications.	

LED indicators

The BPS has seven LED indicators. See “Component descriptions” for the location of the LEDs.

LED	Color	Description
AC	Green	AC power on
NAC1	Yellow	NAC1/AUX1 trouble [1]
NAC2	Yellow	NAC2/AUX2 trouble [1]
NAC3	Yellow	NAC3/AUX3 trouble [1]
NAC4	Yellow	NAC4/AUX4 trouble [1]
BAT	Yellow	Battery trouble. Indicates that the battery level has fallen below acceptable levels.
GND	Yellow	Ground fault. Indicates that a ground fault has been detected on the field wiring.

[1] The NAC LEDs indicate a trouble with the load or external wiring on the NAC/AUX circuit. For circuits configured as NACs, this could be an open circuit trouble, short circuit trouble, or an overload trouble.

For short circuit troubles, the NAC does not activate until the short circuit condition is removed.

For overload troubles, an active NAC is shutdown. After shutdown, if there is no short circuit condition, the NAC reactivates after 30 seconds and checks to see if the overload condition still exists.

For AUX circuits, the trouble indicates an overload condition. The AUX circuit is shutdown for 30 seconds and then is reactivated to see if the overload condition still exists.

Trouble indicating and reporting

When the BPS trouble relay is not dedicated to AC power loss reporting (DIP switch SW2-6 OFF), the trouble conditions listed in the table above are reported through the trouble relay. Other internal troubles that do not have an associated LED are also reported via the BPS trouble relay. Other internal troubles include: DIP switch read trouble, RAM failure, code checksum failure, A to D failure, and battery charger failure.

All troubles are also reported through both sense circuit trouble relays.

Installing the enclosure

When installing this system, be sure to follow all applicable national and local fire alarm codes and standards.

The enclosure can be surface mounted or semiflush mounted. See “Enclosure dimensions” below for details.

To surface mount the enclosure:

1. Position the enclosure on the finished wall surface.
2. Fasten the enclosure to the wall surface where indicated.
3. Install all conduit and pull all wiring into the enclosure before proceeding.

To semiflush mount the enclosure:

1. Frame the interior wall as required to support the full weight of the enclosure and standby batteries.
2. Fasten the enclosure to the framing studs where indicated.
3. Install all conduit and pull all wiring into the enclosure before proceeding.

Enclosure dimensions

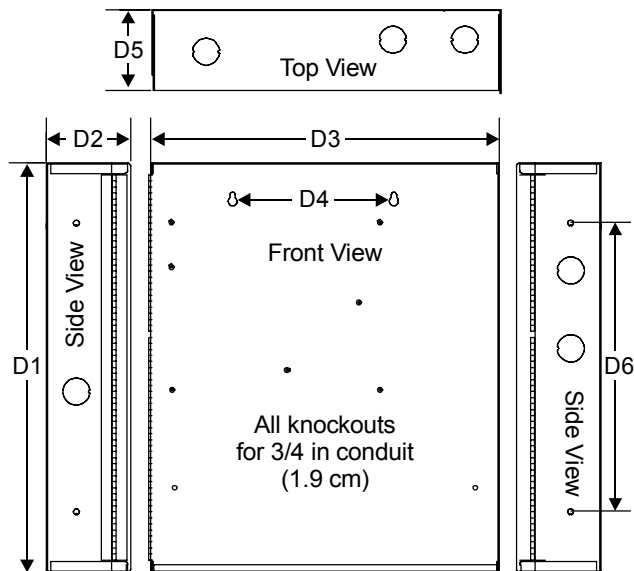

D1	D2	D3	D4	D5	D6
17.0 in (43.2 cm)	3.5 in (8.9 cm)	13.0 in (33.0 cm)	6.5 in (16.5 cm)	3.375 in (8.6 cm)	12.0 in (30.4 cm)

Installing option modules in the enclosure

Up to three option modules can be installed on the mounting brackets inside the enclosure. Depending on the model, the device must be either screw-mounted or snapped to the bracket.

To snap-mount modules to a bracket:

1. Snap the module into a mounting bracket.
2. Connect all wiring. Refer to the module's installation sheet for wiring information or the *Signature Series Component Installation Manual P/N 270497*.

Note: The first module you install must be installed in the top mounting bracket. The second module must be installed in the middle mounting bracket and the third module in the bottom bracket.

Note: Route the wiring around the perimeter of the enclosure, not across the circuit board.

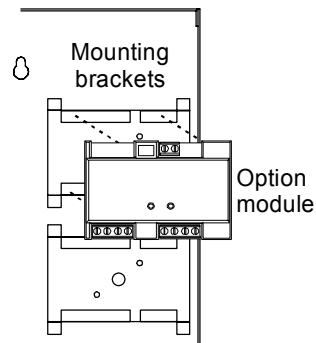

To screw-mount Signature Series modules to a bracket:

1. Remove the module's plastic cover.
2. Remove the circuit board from the plastic backing.
3. Screw the plastic backing to the mounting bracket using two #6, 1/4-inch, flat head sheet metal screws.

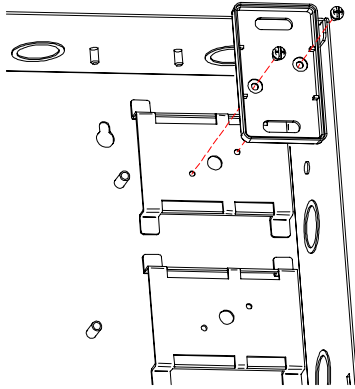

4. Insert the circuit board into the plastic backing.
5. Snap the module's plastic cover into place.
6. Connect all wiring. Refer to the module's installation sheet for wiring information or the *Signature Series Component Installation Manual P/N 270497*.

Note: Route the wiring around the perimeter of the enclosure, not across the circuit board.

Installing the circuit board in the enclosure

You may have to remove the circuit board to install the enclosure. Reinstalling the circuit board in the enclosure must be done with accuracy to avoid causing ground faults or shorts. The screws and standoffs must be installed correctly and in the right positions. Use the diagrams below to install the circuit board.

Complete circuit board installation

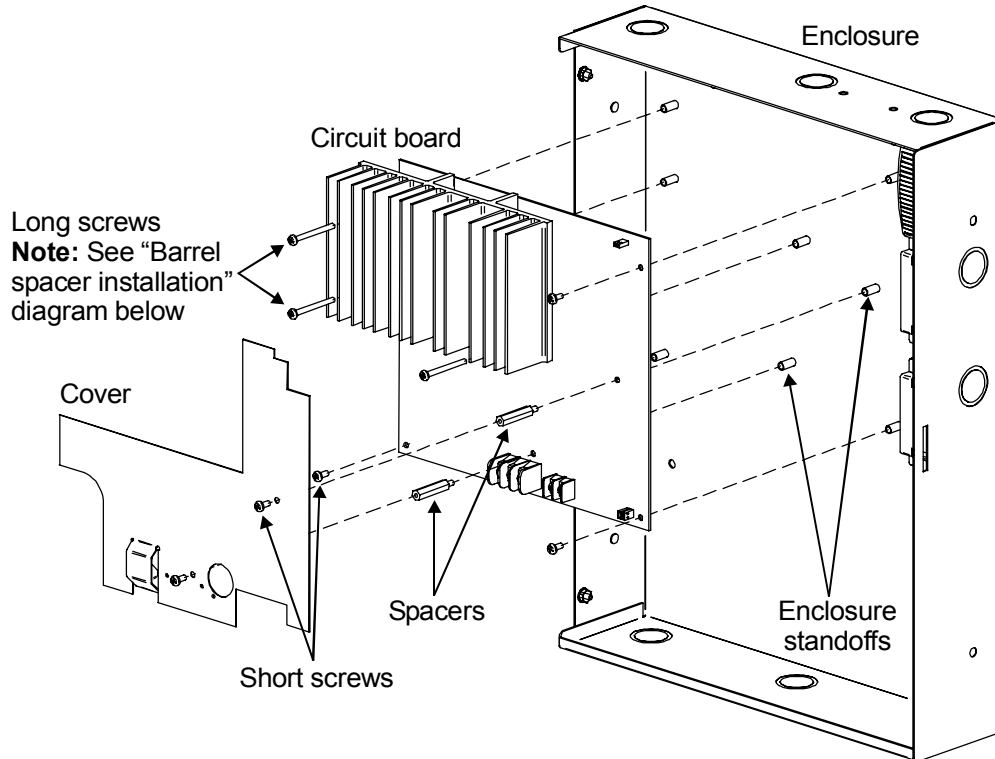

Barrel spacer installation

Note: The barrel spacers must be positioned correctly so that the long screw can pass through the spacer and into the enclosure standoff.

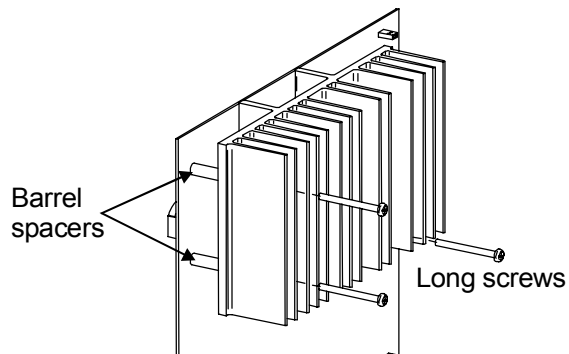

Setting the jumpers

There are four jumpers on the BPS. See “Component descriptions” for the location of the jumpers.

NAC Class A or Class B (JP1 and JP2)

JP1 and JP2 are used to select a Class A, Style Z or Class B, Style Y NAC wiring configuration for all NACs. The default is Class B.

Note: JP1 and JP2 must be positioned to match the SW2-8 DIP switch selection (Class A or Class B).

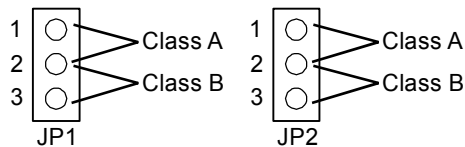

Ground fault enable (JP3)

JP3 is used to set the NAC/AUX circuits for ground fault enabled or disabled operation. The sense inputs are always isolated from local power.

Enabled: Allows the BPS to perform its own ground fault checking. This is the *default* position.

Disabled: Disable the BPS’s ground fault detection if the host panel is detecting system ground faults. Disabling ground fault detection removes the ability of the BPS to detect ground faults and isolates the BPS from earth ground. This is what allows the control panel to do the system’s ground fault checking. If you do not disable ground fault detection when connecting powered devices as shown in the diagram below, you may get excessive ground faults on your system or ground faults on your system may fail to be reported.

Note: NAC circuit ground fault detection is required for all fire and security applications. It is recommended that systems, which are set with ground fault disabled, be tested after installation.

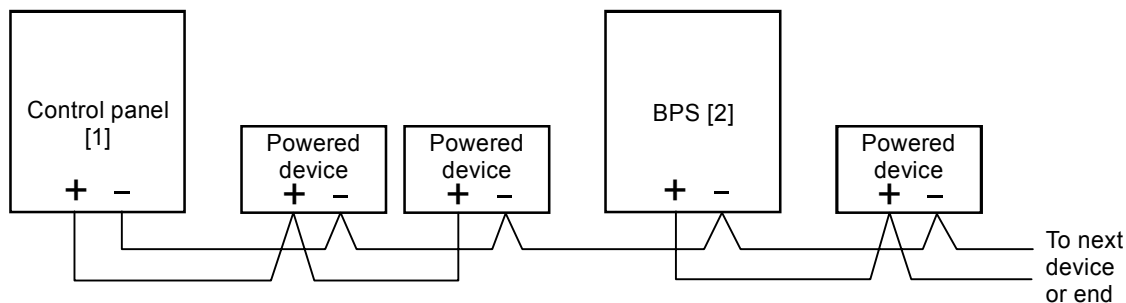

- [1] The control panel is responsible for ground fault detection when your system is wired in this fashion
- [2] Disable the BPS's ground fault jumper (JP3)

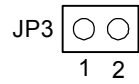

GF disable: *Do not* install jumper

GF enable: Install jumper

Battery charging (JP4)

The battery charging jumper is a small wire that controls how the batteries are charged. Battery size determines whether you must cut the jumper wire or leave it intact.



Cut the jumper wire when using batteries *under 10 Ah*.

Do not cut the jumper wire when using batteries *10 Ah or over*.

Setting the DIP switches

NOTICE TO USERS, INSTALLERS, AUTHORITIES HAVING JURISDICTION, AND OTHER INVOLVED PARTIES

This product incorporates field-programmable options. In order for the product to comply with the requirements in the Standard for Control Units and Accessories for Fire Alarm Systems, UL 864, certain programming features or options must be limited to specific values or not used at all as indicated below.

Programmable feature or option	Permitted in UL 864? (Y/N)	Possible settings	Settings permitted in UL 864
Four second NAC audible synchronization delay [1]	N	On (4 second delay) Off (1 second delay)	Off

[1] This option is controlled by switch SW1-4. See "Synchronization control (SW1-4)" on page 17.

Two eight-position DIP switches are used to configure the BPS. The following sections show the DIP switch settings for the various input and output configurations.

Note: From the factory, all switches are in the OFF position.

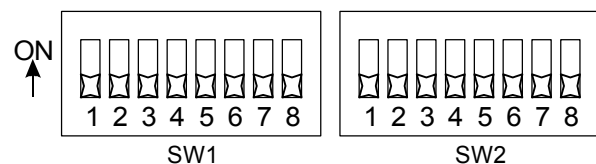

Sense 1 and 2 operation (SW1-1 to 3)

The BPS has three operating modes, as shown in the following table. Switches SW1-1, -2, and -3 determine which mode is used.

Operating mode [1]	Switch setting		
	SW1-1	SW1-2	SW1-3
Correlate mode	OFF	-	-
Genesis Master mode	ON	OFF	ON
Nondelayed mode	ON	ON	-

[1] See the descriptions below for operation details

These switches also determine how Sense 1 and 2 correlate to the NAC circuits. Details for each mode are described below.

Correlate mode

In correlate mode, switches SW1-2 and SW1-3 control which NACs activate when the sense circuits activate. The correlations do not affect output circuits that are operating as AUX circuits.

The following table details which NACs activate when the sense circuits activate.

Sense circuit to NAC correlations					
Switch settings		Class B		Class A	
SW1-2	SW1-3	Sense 1	Sense 2	Sense 1	Sense 2
OFF	OFF	1, 2, 3, 4	1, 2, 3, 4	1/2, 3/4	1/2, 3/4
OFF	ON	1	2, 3, 4	1/2	3/4
ON	OFF	1, 2	3, 4	-	-
ON	ON	1, 2, 3	4	-	-

Genesis Master mode

In Genesis Master mode, Sense 1 is connected to a visible zone and Sense 2 is connected to an audible zone. All NACs are activated when Sense 1 activates. Continuous NACs generate Genesis audible on/off signals based on the Sense 2 input circuit.

Nondelayed mode

Nondelayed mode is intended to support coders. In this mode, there is no delay between activation of the sense input and activation of the NAC.

In nondelayed mode, switch SW1-3 controls which NACs activate when the sense circuits activate. The correlations do not affect output circuits that are operating as AUX circuits.

The following table details which NACs activate when the sense circuits activate.

Sense circuit to NAC correlations				
SW1-3 setting	Class B		Class A	
SW1-3	Sense 1	Sense 2	Sense 1	Sense 2
OFF	1, 2, 3, 4	1, 2, 3, 4	1/2, 3/4	1/2, 3/4
ON	1, 2	3, 4	1/2	3/4

In nondelayed mode, SW2-5 can be used to generate sync pulses for NACs configured in continuous mode. This supports applications that include Genesis strobes and conventional audibles. For this operation, the NACs for the audible signals must be configured in sense follow mode. There is no delay for either the visibles or the audibles.

Synchronization control (SW1-4)

Switch SW1-4 controls the synchronization of signals with either one- or four-second delay times. See the topic "Understanding BPS synchronization" for more information.

Note: When using nondelayed mode, this switch is inactive.

Switch setting	Operation description
ON	NACs turn on 4 seconds after the sense input is activated (e.g. Genesis NACs sync with the second round of the temporal signal)
OFF	NACs turn on 1 second after the sense input is activated (e.g. the Genesis NACs sync with the second flash of the Genesis strobes)

NAC circuit operation (SW1-5 to 8 and SW2-1 to 4)

Switch SW1-5 to 8 and SW2-1 to 4 control NAC operation.

Operating mode	NAC1		NAC2		NAC3		NAC4	
	SW1-5	SW1-6	SW1-7	SW1-8	SW2-1	SW2-2	SW2-3	SW2-4
Sense Follow [1]	OFF	OFF	OFF	OFF	OFF	OFF	OFF	OFF
Continuous [1]	OFF	ON	OFF	ON	OFF	ON	OFF	ON
Temporal or California [1] [2]	ON	OFF	ON	OFF	ON	OFF	ON	OFF
Auxiliary [1]	ON	ON	ON	ON	ON	ON	ON	ON

[1] See the descriptions below for operation details

[2] BPS models BPS6CAA and BPS10CAA use California operation in place of temporal. For temporal operation, set the BPS to sense follow mode and use an external temporal source to activate the BPS sense circuit to generate the temporal pattern.

Sense follow mode

In sense follow mode, NACs are activated following the sense circuits that are defined to turn on the NACs. The NACs turn on with a one- or four-second (does not comply with UL864 9th edition) delay to allow Genesis strobes to synchronize on the NAC side and sense side. In this mode, a continuous input, 120 ppm, temporal, or coded input can be used.

Note: Sense follow must be used when the sense circuit is connected to a SIGA-CC1S, Genesis G1M-RM, FireShield panel, or a BPS generating Genesis sync pulses.

Continuous mode

In continuous mode, NACs are activated following the sense circuits in continuous mode. They activate one or four (does not comply with UL864 9th edition) seconds after the sense input activates and restore seven seconds after the sense input restores.

Temporal mode

In temporal mode, NACs are activated following the sense circuits in temporal mode. They activate one or four (does not comply with UL864 9th edition) seconds after the sense input activates and

restore seven seconds after the sense input restores. NACs generate temporal output as defined by NFPA.

California mode

In California mode, NACs generate the California output: 10 seconds of 120 ppm followed by five seconds off.

Auxiliary

In auxiliary mode, NACs turn on during power up. Sync pulses are not generated. Aux circuits can be configured to stay active during a power fail or load shed on a power fail (after a 30 second delay). Aux circuits are load shed when the system reaches low battery to prevent deep discharge of the batteries.

Genesis mode for continuous NACs (SW2-5)

Switch SW2-5 controls NAC operation for Genesis synchronization in continuous mode.

Switch setting	Operation description
ON	Continuous NACs are Genesis strobe or horn/strobe circuits. Continuous NACs generate a Genesis sync pulse. In Genesis Master mode, continuous NACs generate Genesis audible on/off signals based on the Sense 2 input circuit.
OFF	Continuous NACs do not generate Genesis signaling pulses

AC power loss reporting (SW2-6)

Switch SW2-6 controls when a report is sent to the system for an AC power loss.

Switch setting	Operation description
ON	The BPS trouble relay is dedicated to AC power loss reporting. The trouble relay switches within 20 seconds when AC fails or restores. The sense circuits immediately signal a fault condition for any <i>non-AC</i> power loss faults. If AC power fails, the sense circuits signal a fault condition after three hours of power loss.
OFF	The trouble relay operates for any trouble on the BPS. The sense circuits signal a fault for any troubles.

Auxiliary control during AC power loss (SW2-7)

Switch SW2-7 controls auxiliary outputs during AC loss.

Note: The 200 mA continuous AUX circuit is not affected by AC power loss.

Switch setting	Operation description
ON	Auxiliary outputs turn off 30 seconds after power fail
OFF	Auxiliary outputs stay on after AC power fail until the battery is less than 18.4 VDC

Class A or B NAC configuration (SW2-8)

Switch SW2-8 controls NAC Class A or B operation for all NACs.

Note: Jumpers JP1 and JP2 must be set to match the operation of this switch.

Switch setting	Operation description
ON	Class A NACs
OFF	Class B NACs

Wire routing

To avoid noise, separate high current input or output wiring from low current wiring. Separate power-limited from nonpower-limited wiring.

Wiring within the enclosure should be routed around the perimeter of the enclosure, not across the circuit board.

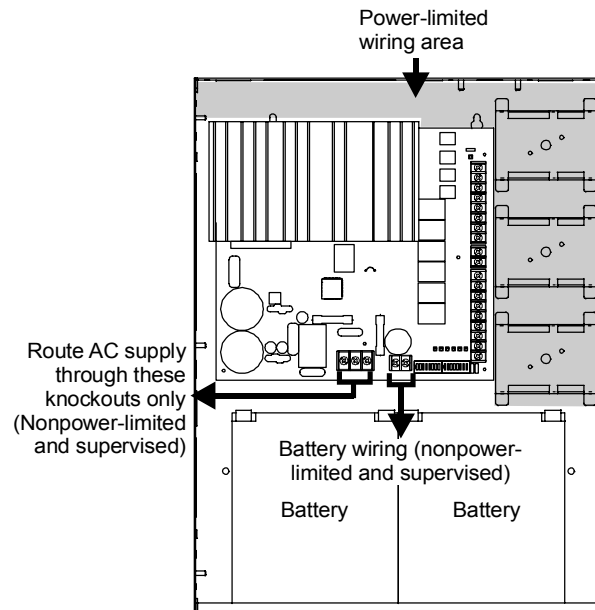

Notes

1. Maintain 1/4-inch (6 mm) spacing between power-limited and nonpower-limited wiring or use type FPL, FPLR, or FPLP cable per NEC
2. NAC circuits are power-limited and supervised for opens, shorts, and overcurrents. When configured as auxiliary power circuits, they are power-limited and supervised for shorts and overcurrents.
3. Source must be power-limited. Source determines supervision.
4. Position the battery terminals towards the door

Connecting the field wiring

AC power wiring

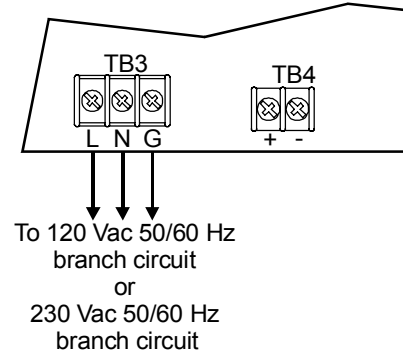

Caution: Break the wire run at each terminal connection to provide proper connection supervision. Do not loop wires under the terminals.

Battery wiring

Two backup batteries are required with the BPS. The largest batteries that fit in the BPS enclosure are 10 Ah. Batteries larger than 10 Ah must be installed in a BC-1 or BC-2 battery cabinet.

Notes

- Batteries should be replaced every five years
- Refer to local and national codes for battery maintenance requirements

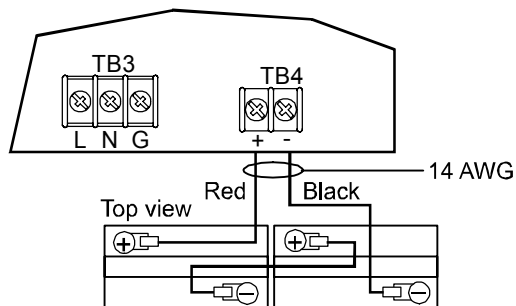

Caution: For proper battery charging, the battery charging jumper wire (JP4) must be set according to the battery size you are using. Refer to "Setting the jumpers" for details about jumper JP4.

NAC Class B (Style Y) wiring

Connect a single NAC circuit to one NAC output. Terminate the circuit with a 15 kΩ EOL resistor.

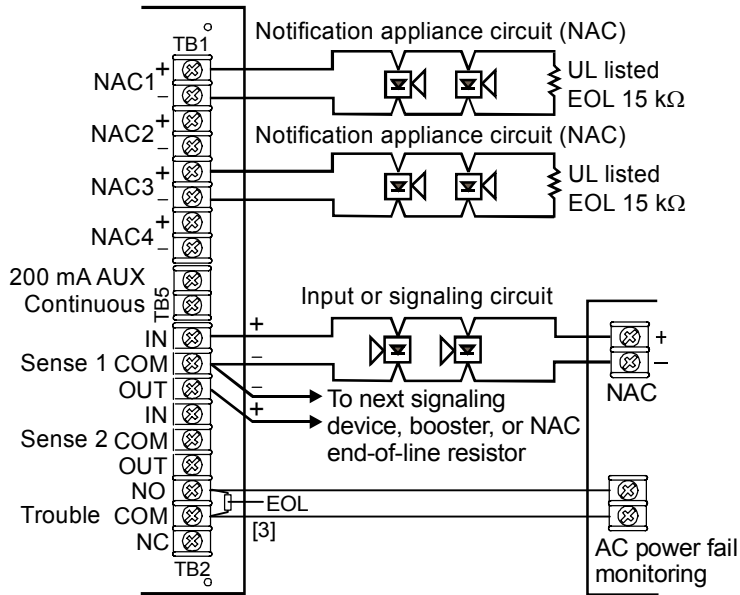

NAC wiring notes

1. A trouble on the booster power supply is sensed on the existing control panel's NAC circuit causing a NAC trouble on that panel. This removes the need to separately monitor the trouble contact except for AC power failure (see [3] below).

In an alarm condition, the booster power supply allows NAC current to move downstream to devices connected to the existing control panel's NAC circuit.

2. Refer to the connected control panel's documentation for more details on NAC wiring

- [3] The AC power failure panel connection annunciates at the panel but does not report off premises for a predetermined time period in U.S. fire applications

NAC Class A (Style Z) wiring

Connect one NAC circuit to one NAC output, either NAC1 or NAC3. Terminate the circuit at the NAC2 or NAC4 terminal screw, respectively.

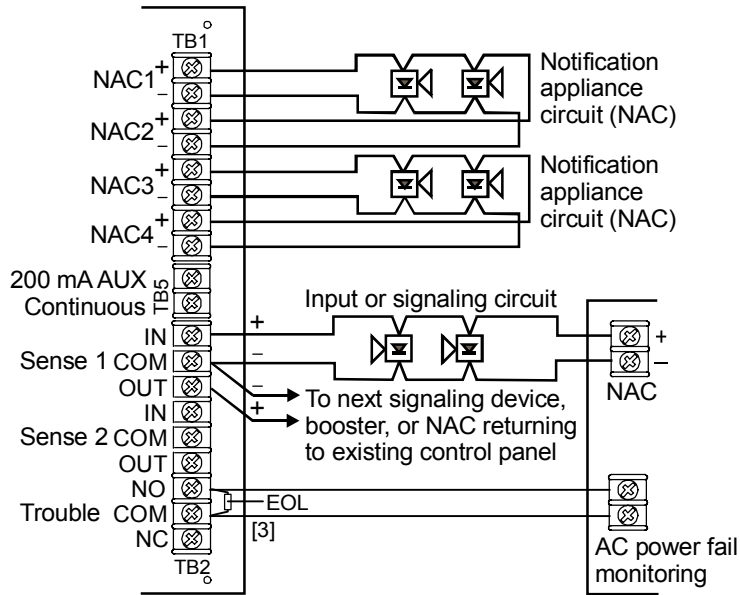

AUX power wiring

Dedicated AUX power

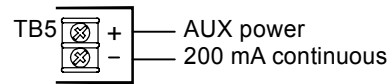

NAC configured as AUX power

Each NAC can be configured through a DIP switch for use as AUX power. A DIP switch also controls AUX operation during AC power loss. See “Setting the DIP switches” for details.

This auxiliary configuration is compatible with fire alarm, security, and access control applications, which can be combined in a single system, if all of the devices are listed.

Note: When a NAC is configured as an AUX power circuit, a UL listed EOL relay (PAM1, 6254A-003, or 73402A) is recommended for supervision of the circuit.

Trouble relay wiring with four AUX circuits

When all four NAC/AUX circuits are configured as AUX circuits and DIP switch SW2-6 is ON, a SIGA-CT2 module must be used to monitor the sense 1 trouble contacts and the trouble relay.

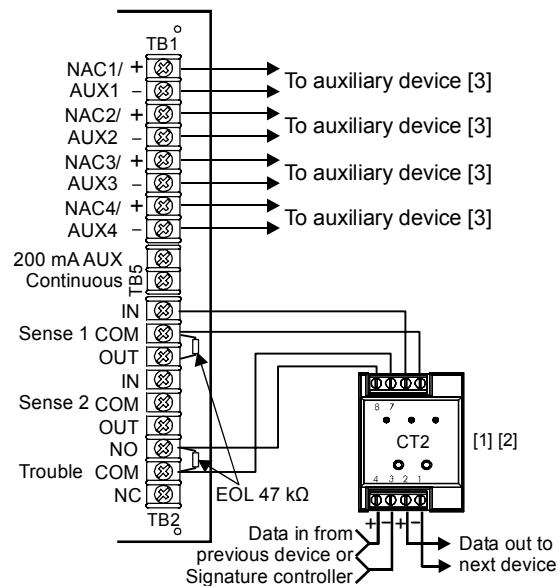

Notes

- [1] Modules must be wired and programmed on the Signature controller for proper operation
- [2] AC power loss causes circuit 2 on the CT2 to report a trouble to the control panel (see panel programming). All other BPS

troubles cause circuit 1 on the CT2 to report a trouble to the panel.

- [3] The NAC/AUX circuit must be configured for AUX operation using the DIP switches. See "Setting the DIP switches" for details.

Common trouble relay wiring

The BPS has a Form C common trouble relay that provides a normally open and normally closed contact. The trouble relay switches under any trouble condition when DIP switch SW2-6 is off. When the switch is on, the BPS trouble relay is dedicated to AC power loss reporting. The trouble relay switches within 20 seconds when AC fails or restores. The sense circuits immediately signal a fault condition for any *non-AC* power loss faults. When AC power fails, the sense circuits signal a fault condition after three hours of power loss.

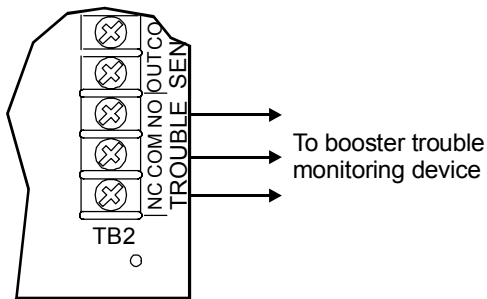

Sense circuit wiring

The BPS has two sense circuits Class B, Style A (Sense 1 and Sense 2). Sense circuit operation is controlled by the BPS's DIP switches. Sense activation of existing NAC circuits reports a trouble condition to the control panel using these circuits.

Note: Any BPS trouble opens the sense circuit, which sends a trouble event message to the control panel, indicating that a trouble exists on that circuit.

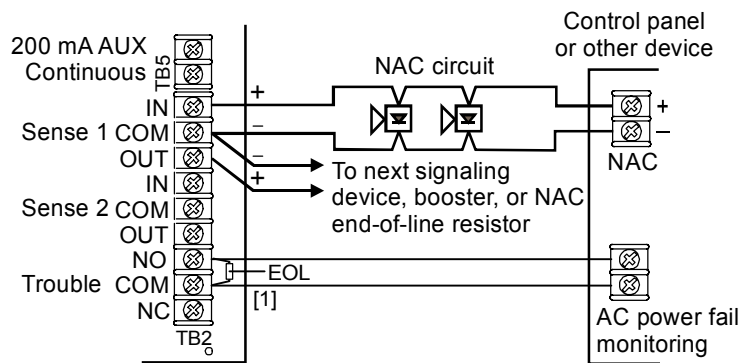

- [1] The AC power failure panel connection annunciates at the panel but does not report off premises for a predetermined time period in U.S. fire applications

Tests for grounds, opens, and shorts

The following are testing procedures for ground fault, open circuit, and short circuit indications.

Ground fault test: Directly short one leg of the circuit to chassis ground. The ground fault and trouble fault LEDs must light.

NAC open circuit test: Remove the EOL resistor from the last device on the circuit. The trouble LED must light.

NAC short circuit test: Place a short across each NAC output individually. The individual NAC LED must light.

AUX power short circuit test: This test applies to NAC outputs configured as AUX outputs. It does not apply to the 200 mA AUX Continuous output. Place a short across each NAC/AUX output individually. The corresponding individual NAC/AUX LED must light.

NAC wiring using CC1(S) modules

The following wiring diagrams show Signature Series CC1(S) module connections. However, other Signature Series signal modules can be used.

Single CC1(S) using the BPS's 200 mA AUX Continuous circuit

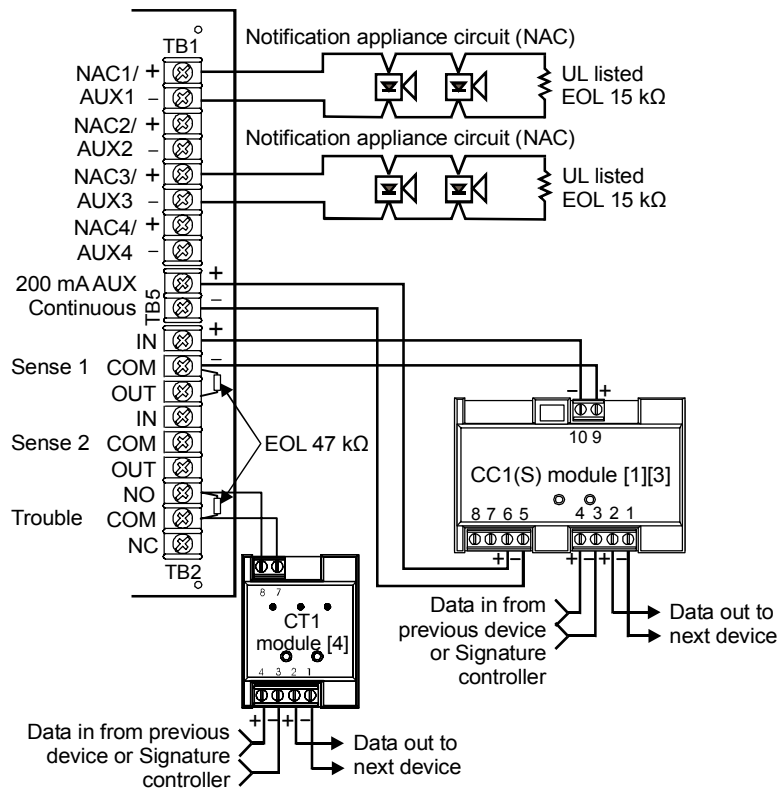

Notes

- [1] Modules must be wired and programmed on the Signature controller for proper operation
2. Any BPS trouble causes the CC1(S) supervision to report a trouble to the main control panel when DIP switch SW2-6 is on. AC power failure is delayed for three hours.
- [3] CC1(S) wiring must be within three feet of the BPS enclosure and in conduit or mounted within the BPS's enclosure. If CC1(S) wiring is more than three feet from a BPS enclosure, then a separate listed EOL relay (PAM1, 6254A-003, or 73402A) or equivalent must be used to supervise the 200 mA AUX circuit wiring.
- [4] When configured for AC power loss reporting using the trouble relay (DIP switch SW2-6 ON), the CT1 module supervises and reports the AC power loss to the control panel. *When DIP switch SW2-6 is OFF, the CT1 module is not required.*

Multiple CC1(S) modules using the BPS's sense inputs

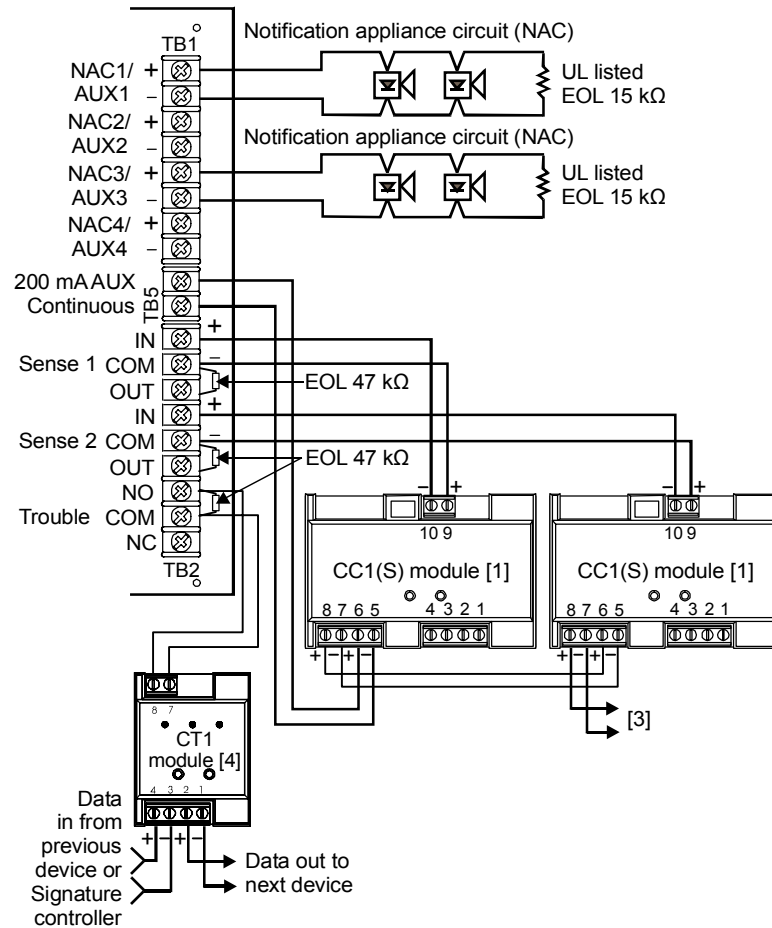

Notes

- [1] Modules must be wired and programmed on the Signature controller for proper operation
2. Any BPS trouble causes the CC1(S) supervision to report a trouble to the main control panel when DIP switch SW2-6 is on. AC power failure is delayed for three hours.
- [3] CC1(S) wiring must be within three feet of the BPS enclosure and in conduit or mounted within the BPS's enclosure. If CC1(S) wiring is more than three feet from a BPS enclosure, then a separate listed EOL relay (PAM1, 6254A-003, or 73402A) or equivalent must be used to supervise the 200 mA AUX circuit wiring.
- [4] When configured for AC power loss reporting using the trouble relay (DIP switch SW2-6 ON), the CT1 module supervises and reports the AC power loss to the control panel. *When DIP switch SW2-6 is OFF, the CT1 module is not required.*

Multiple CC1(S) modules using one of the BPS's NAC/AUX circuits

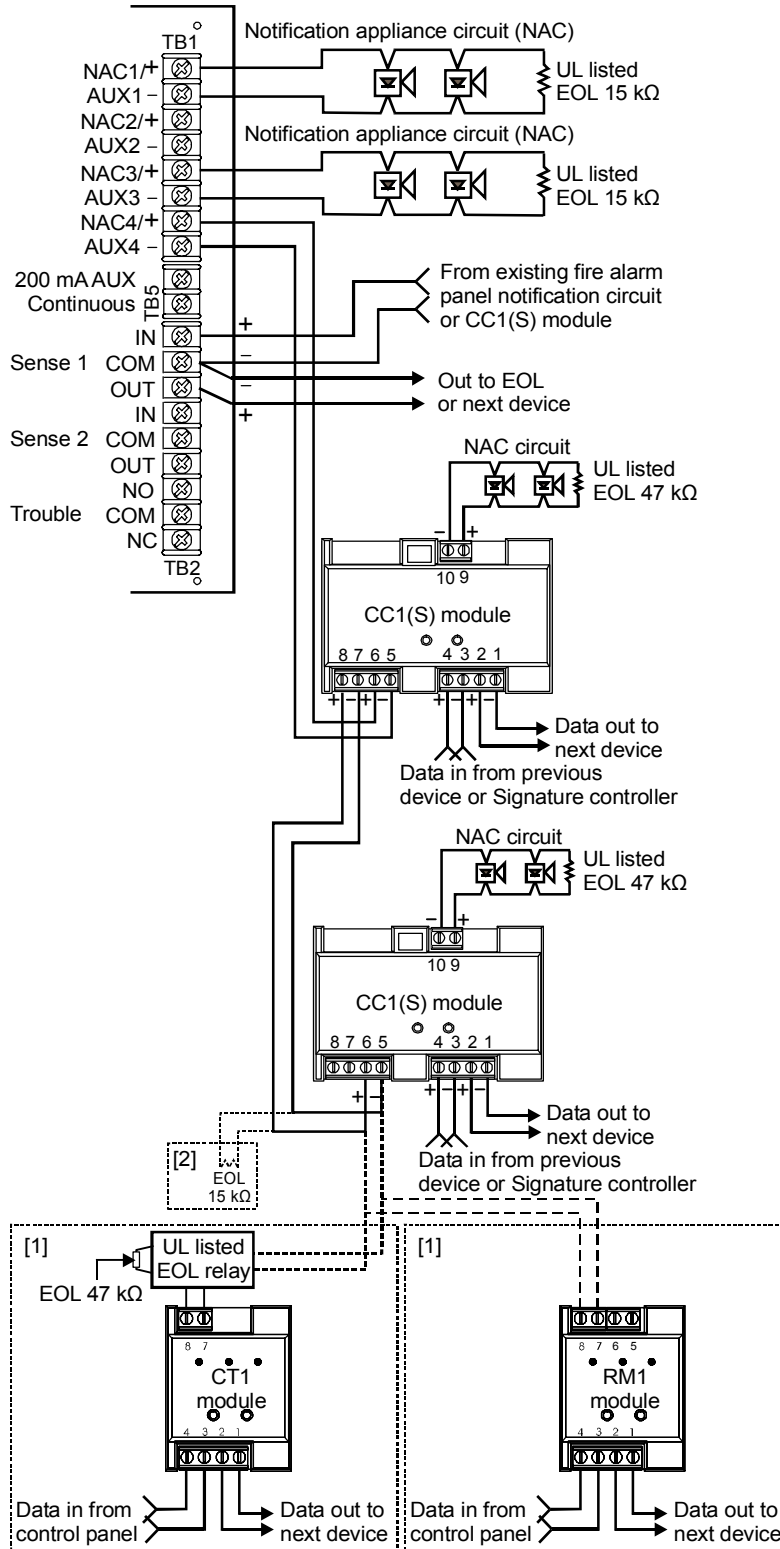

Notes

- [1] When a booster power supply output is programmed as an AUX output, a listed EOL relay (PAM1, 6254A-003, or 73402A) or equivalent must be used to supervise the AUX output
- [2] When a booster power supply output is programmed as an NAC output, a 15 kΩ EOL resistor must be used for supervision

Installing the 3-TAMP tamper switch

The 3-TAMP tamper switch is used to detect an open enclosure door for security purposes.

Note: The 3-TAMP tamper switch *must* be used for security applications and connected to a SIGA-SEC2 module mounted in the enclosure.

To install the tamper switch:

1. Install an EOL resistor on the 3-TAMP. Refer to the *3-TAMP Installation Sheet* (P/N 387422) for more information.
2. Position the tamper switch over the mounting standoffs. See the diagram below.
3. Use the two locking nuts provided to secure the tamper switch. See the diagram below.
4. Connect all wiring to the tamper switch. Refer to the *3-TAMP Installation Sheet* (P/N 387422) for details on wiring the tamper switch.

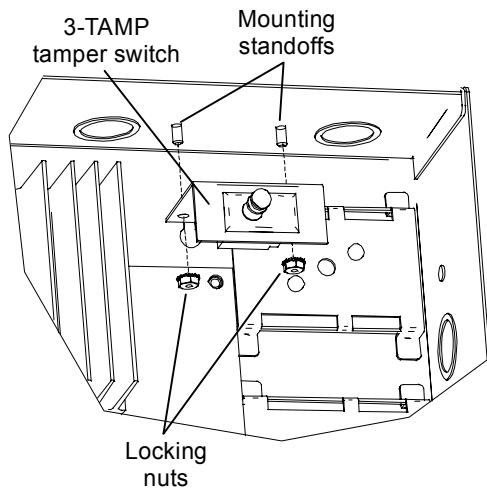

Battery calculation worksheet

Supervisory (AUX1, AUX2, AUX3, AUX4)			
Note: Only add auxiliary current if SW2-7 is OFF. Auxiliary output stays on after AC power failure.			
Device type	Quantity	Current (mA)	Total/device
Total AUX current (0 if switch SW2-7 is off, maximum of 8 A):			mA (A)
Number of circuits set to AUX		35 mA (per AUX circuit)	mA (B)

200 mA AUX			
Device type	Quantity	Current (mA)	Total/device
Total 200 mA AUX current:			mA (C)

Rated base BPS supervisory current:		70 mA (D)
Total supervisory current (A + B + C + D):		mA (E)
Hours of supervisory:		Hrs (F)
Supervisory mAh required (E x F):		mAh (G)

Alarm (NAC1, NAC2, NAC3, NAC4)			
Device type	Quantity	DC current (mA, RMS)	Total/device
Total NAC current:			mA (H)

Rated base BPS alarm current:		270 mA (J)
Total alarm current (E + H + J):		mA (K)
Minutes of alarm:		Min (L)
Hours of alarm (L/60):		Hr (M)
Alarm mAh required (K x M):		mAh (N)

Total battery mAh required (N + G):		mAh (O)
Total battery Ah required (O/1000):		Ah (P)
Supervisory battery current (E/1000):		A (Q)

To use the load current table below: First, select the column where the load is greater than or equal to (Q). Second, select the row from that column where the capacity is greater than or equal to (P). Third, select the corresponding battery size.

Battery size	Load current (amps)													
	0.2	0.4	0.6	0.8	1	2	3	4	5	6	7	8	9	10
6.5 Ahr	5.4	5.3	5.2	5.0	4.8	4.3	3.9	3.6	3.3	3.0	2.8	2.6	2.5	2.3
10 Ahr	8.3	8.3	8.1	7.9	7.7	7.1	6.6	6.2	5.8	5.5	5.2	5.0	4.7	4.5
17 Ahr	14.1	14.1	14.1	14.1	13.5	12.8	12.3	11.8	11.3	10.9	10.5	10.1	9.8	9.5
24 Ahr	20.0	20.0	20.0	20.0	20.0	18.7	18.1	17.5	17.0	16.5	16.0	15.6	15.2	14.8
40 Ahr [1]	33.0	33.0	33.0	33.0	33.0	33.0	32.0	31.0	30.0	29.0	28.5	28.0	27.5	27.0
50 Ahr [1]	42.0	42.0	42.0	42.0	42.0	42.0	41.0	40.0	39.0	38.0	37.0	36.5	36.0	35.5
55 Ahr [1]	46.0	46.0	46.0	46.0	46.0	46.0	45.0	44.0	43.0	42.0	41.0	40.5	40.0	39.5
65 Ahr [1]	54.0	54.0	54.0	54.0	54.0	54.0	54.0	53.0	52.0	51.0	50.0	49.0	48.5	48.0
[1] Batteries larger than 24 Ahr are not intended for use on fire and security applications.														

Notification appliance circuit calculations

Introduction

This topic shows you how to determine the maximum cable length of a notification appliance circuit (NAC) for a given number of appliances.

Two methods are presented: worksheet and equation. The worksheet method is simpler, but your installation must meet the criteria listed on the worksheet. If your installation does not meet these criteria, you need to use the equation method.

The methods given here determine cable lengths that work under all operating conditions. The calculations ensure that the required operating voltage and current will be supplied to all notification appliances. To do this, we assume these two worst-case conditions:

- The voltage at the NAC terminals is the minimum provided by the power supply
- The notification appliances are clustered at the end of the NAC cable

Other, more detailed methods that distribute the appliance load along the NAC cable may indicate that longer cable runs are possible.

What you'll need

Appliance and cable values

Whether you use the worksheet method or the equation method, you'll need to know:

- The minimum operating voltage required for the appliances
- The maximum operating current drawn by each appliance
- The resistance per unit length of the wire used (Ω/ft)

This information can be found on the appliance installation sheets and on the cable specification sheet.

Power supply values

For either method, you'll need some fixed or calculated operating values for your specific power supply. The fixed values are:

- Maximum voltage = 26.3 V
- Source voltage = 19.7 V
- Load factor = 0.59 V/A
- Power type = DC

The *maximum voltage* is the highest voltage measured at the NAC terminals. This value is not used in the calculations, but is given so you can ensure appliance compatibility.

The *source voltage* is the theoretical operating minimum for the power supply, and is calculated as 85% of 24 volts minus the diode drop.

The *load factor* is a measure of how the power supply voltage reacts when a load is applied. The load factor measures the voltage drop per ampere of current drawn by the load.

The *power type* reflects the type of power supplied to the NAC terminals at minimum voltage. The current draw of notification appliances can vary substantially with the type of power supplied: full-wave rectified (VFWR) or direct current (VDC). It is important to know the power type at minimum terminal voltage.

You'll need to calculate the following values relating to your power supply and to the NAC circuit current. These are:

- Minimum voltage
- Voltage drop

The *minimum voltage* is the lowest voltage measured at the NAC terminals when the power supply is under the maximum load for that circuit (i.e. for the appliances that constitute the NAC.)

The *voltage drop* is the difference between the minimum voltage and 16 V. This value is for use with the worksheet only.

Worksheet method

Use this worksheet to determine the maximum cable length of a notification appliance circuit for a given number of appliances.

Use this worksheet only if all the appliances are regulated. That is, they must have a minimum operating voltage of 16 V. For other appliances, use the "Equation method."

Worksheet 1: NAC cable length

		NAC1	NAC2	NAC3	NAC4	
Total operating current [1]		<input type="text"/>	<input type="text"/>	<input type="text"/>	<input type="text"/>	A
Load factor	×	<input type="text" value="0.59"/>	<input type="text" value="0.59"/>	<input type="text" value="0.59"/>	<input type="text" value="0.59"/>	V/A
Load voltage drop	=	<input type="text"/>	<input type="text"/>	<input type="text"/>	<input type="text"/>	V
Source voltage		<input type="text" value="19.7"/>	<input type="text" value="19.7"/>	<input type="text" value="19.7"/>	<input type="text" value="19.7"/>	V
Load voltage drop	-	<input type="text"/>	<input type="text"/>	<input type="text"/>	<input type="text"/>	V
Minimum voltage	=	<input type="text"/>	<input type="text"/>	<input type="text"/>	<input type="text"/>	V
Regulated appliance voltage	-	<input type="text" value="16.0"/>	<input type="text" value="16.0"/>	<input type="text" value="16.0"/>	<input type="text" value="16.0"/>	V
Voltage drop [2]	=	<input type="text"/>	<input type="text"/>	<input type="text"/>	<input type="text"/>	V
Total operating current	÷	<input type="text"/>	<input type="text"/>	<input type="text"/>	<input type="text"/>	A
Maximum resistance	=	<input type="text"/>	<input type="text"/>	<input type="text"/>	<input type="text"/>	Ω
Wire resistance (Ω/ft) [3]	÷	<input type="text"/>	<input type="text"/>	<input type="text"/>	<input type="text"/>	
Maximum wire length	=	<input type="text"/>	<input type="text"/>	<input type="text"/>	<input type="text"/>	ft
	÷	<input type="text" value="2"/>	<input type="text" value="2"/>	<input type="text" value="2"/>	<input type="text" value="2"/>	
Maximum cable length	=	<input type="text"/>	<input type="text"/>	<input type="text"/>	<input type="text"/>	ft

[1] Total of the maximum operating currents for all appliances as specified for DC power. See the appliance installation sheets for operating currents.

[2] This voltage drop is valid for regulated notification appliances only. For special application appliances, see "Equation method," later in this topic.

[3] Use the manufacturer's published wire resistance expressed in ohms per foot. For typical values, see Table 1 on page 36.

Equation method

Appliance operating voltage and current

Regulated notification appliances have an operating range from 16 V to 33 V. Use 16 V as the minimum appliance voltage when using regulated notification appliances.

When using special application appliances, refer to the installation sheets to determine the minimum appliance voltage required.

What if there are different types of appliances in the NAC, and each type has a different minimum operating voltage? In this case, use the *highest* minimum voltage required by any appliance.

The total current requirement for the appliances will be the sum of the individual maximum currents drawn by each appliance when using DC power. Use the maximum current for the appliance over the 16 V to 33 V range.

If all appliances draw the same maximum current, the total current is the maximum current multiplied by the number of appliances. If different appliance types have different maximum currents, the total current is the sum of the maximum current for each appliance type multiplied by the number of appliances of that type.

Wire resistance

Typical wire resistances are shown in the following table.

Table 1: Typical wire resistances

Wire gauge (AWG)	Resistance 1-strand uncoated copper		Resistance 7-strand uncoated copper	
	Ω per foot	Ω per meter	Ω per foot	Ω per meter
12	0.00193	0.00633	0.00198	0.00649
14	0.00307	0.01007	0.00314	0.01030
16	0.00489	0.01604	0.00499	0.01637
18	0.00777	0.02549	0.00795	0.02608

When performing these calculations, always refer to the actual cable supplier documentation and use the actual Ω/ft (or Ω/m) for the cable being used.

Calculating cable length

To calculate the maximum NAC cable length:

1. Calculate the total current (I_{tot}) as the sum of the maximum operating currents for all the appliances.

$$I_{tot} = \Sigma I_a$$

Where:

I_a = appliance maximum current

See the appliance installation sheets for I_a . Remember to use the maximum operating current specified for DC power.

2. Calculate the minimum voltage (V_m).

$$V_m = V_s - (I_{tot} \times K)$$

Where:

V_s = source voltage

I_{tot} = total current (from above)

K = load factor

For the power supply, V_s is 19.7 V and K is 0.59 V/A.

3. Calculate the allowable voltage drop (V_d) between the power supply and the appliances.

$$V_d = V_m - V_a$$

Where:

V_m = minimum voltage (from above)

V_a = appliance minimum voltage

For regulated notification appliances, V_a is 16 V. For special application appliances, V_a is the lowest operating voltage specified on the appliance installation sheet.

4. Calculate the maximum resistance (R_{max}) for the wire.

$$R_{max} = V_d / I_{tot}$$

Where:

V_d = voltage drop

I_{tot} = total current

5. Calculate the maximum length of the cable (L_c), based on the maximum resistance allowed, the resistance of the wire, and the number of wires in the cable (two).

$$L_c = (R_{max} / R_w) / 2$$

Where:

R_{max} = maximum resistance

R_w = wire resistance factor

Example: You're using regulated notification appliances. Assume that the maximum operating current for each appliance is 100 mA for DC power, and that 20 appliances will be placed on the NAC. The cable is 12 AWG wire, and the manufacturer specifies a wire resistance factor of 0.002 Ω /ft.

$$\begin{aligned} I_{\text{tot}} &= \Sigma I_a \\ &= 20 \times 0.1 \text{ A} \\ &= 2 \text{ A} \end{aligned}$$

$$\begin{aligned} V_m &= V_r - (I_{\text{tot}} \times K) \\ &= 19.7 \text{ V} - (2 \text{ A} \times 0.59 \text{ V/A}) \\ &= 19.7 \text{ V} - 0.76 \text{ V} \\ &= 18.94 \text{ V} \end{aligned}$$

$$\begin{aligned} V_d &= V_m - V_a \\ &= 18.94 \text{ V} - 16.0 \text{ V} \\ &= 2.94 \text{ V} \end{aligned}$$

$$\begin{aligned} R_{\text{max}} &= V_d / I_{\text{tot}} \\ &= 2.94 \text{ V} / 2.0 \text{ A} \\ &= 1.47 \Omega \end{aligned}$$

$$\begin{aligned} L_c &= (R_{\text{max}} / R_w) / 2 \\ &= (1.47 \Omega / 0.002 \Omega/\text{ft}) / 2 \\ &= (367.5 \text{ ft}) / 2 \\ &= 367.5 \text{ ft} \end{aligned}$$

So the maximum wire run for this NAC would be 367.5 ft (rounding down for safety).

Understanding BPS synchronization

When using Genesis devices, the activation of the visible and audible output circuits on the BPS are determined by how the BPSs are connected. No matter how BPSs are connected, their outputs are “in sync” but there is an output activation delay of either one or four seconds. This section details how BPS outputs work based on how they are connected.

Connection of booster power supplies

Multiple BPSs can be connected in parallel. How you connect your BPSs affects the synchronization of your system’s outputs.

BPSs can be connected in parallel using their sense circuits. When connected via the sense circuits, all BPS outputs have either a one or four second (does not comply with UL864 9th edition) delay from the time the driver NAC turns on to the time the BPS NACs turn on. Delay time is controlled by DIP switch SW1-4. See “Setting the DIP switches” for more information.

BPSs connected in parallel with sense circuits

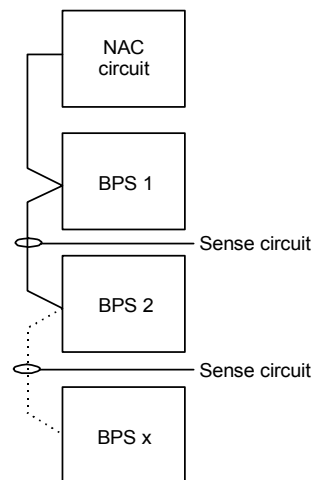

Notes

- To ensure all BPSs are synchronized in a Genesis application, the driving NAC must provide the Genesis synchronization pulse. Therefore, the BPSs must not be set to Genesis mode.
- The quantity of BPSs that can be connected is limited by wire run length and available current

Synchronization of visible outputs

In the figure below, all visible output circuits on each BPS activate with a one second delay. This requires that the BPSs be connected in parallel through their sense circuits.

Visible output synchronization with a one-second output activation delay when BPSs are connected in parallel through the BPS sense circuits

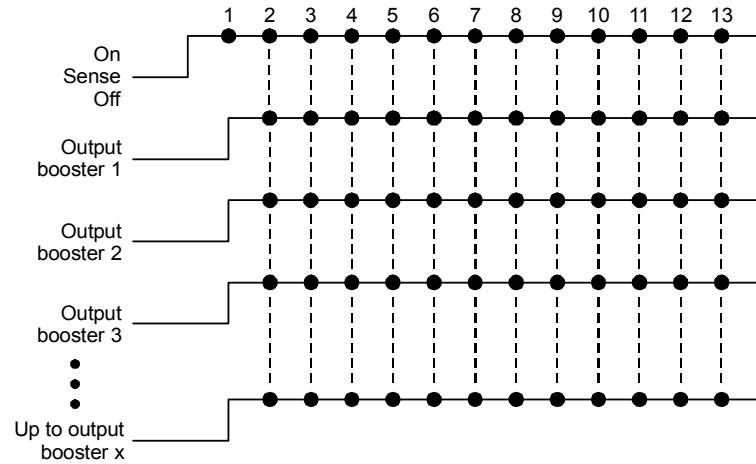

Sync diagrams key

- = Strobe flash
- ▬ = Audible tone

Synchronization of visible and audible outputs

One-second delay of outputs

In the figure below, all visible and audible circuits are synchronized with a one second output activation delay when the BPSs are connected in parallel through their sense circuits.

Note: Delay time is controlled by DIP switch SW1-4. See “Setting the DIP switches” for more information.

Visible and audible output synchronization with a one-second output activation delay when BPSs are connected in parallel through the BPS sense circuits

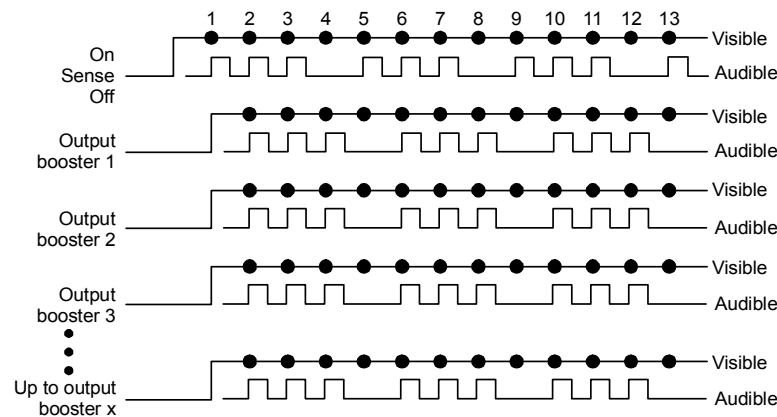

Four-second delay of outputs (temporal setting)

Note: Four-second delay operation does not comply with UL864 9th edition.

In Figure Sync6 below, all visible and audible circuits are synchronized with a four second output activation delay when the BPSs are connected in parallel through their sense circuits.

Note: Delay time is controlled by DIP switch SW1-4. See “Setting the DIP switches” for more information.

Visible and audible output synchronization with a four-second output activation delay when two BPSs are connected in parallel through the BPS sense circuits

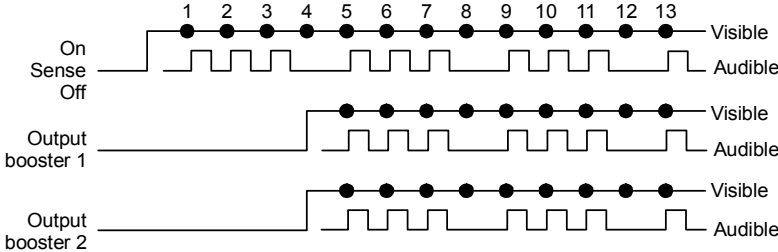





Applications

Disclaimer: The applications in this section are shown in general terms. It is the responsibility of the installer and designer to adhere to the local and national codes when applying and installing the BPS.

Key

The following symbols and notations are found on the application diagrams in this section.

Device labels

Symbol	Description
	Visible device
	Audible device
	Genesis visible/audible device
	Visible or audible device
	Device generating the Genesis sync pulse Note: When this symbol appears on a BPS, the Genesis sync pulse is controlled by DIP switch SW2-5.

BPS modes (controlled by DIP switch)

Notation	Description
COR	Correlate mode
GM	Genesis Master mode
ND	Nondelayed mode

NAC settings (controlled by DIP switch)

Notation	Description
SF	Sense follow
CONT	Continuous
Temp/Cal	Temporal/California
AUX	Auxiliary

Genesis circuit notification

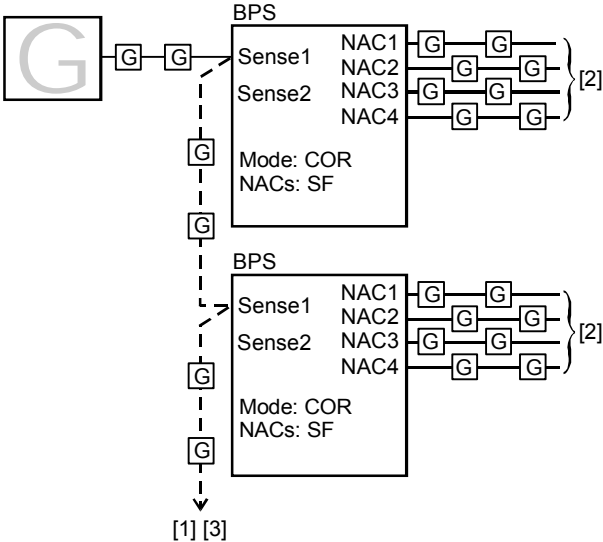

Notes

- [1] The maximum number of BPSs that can be connected on a single NAC from sense circuit to sense circuit is limited by available current and wire run length
- [2] To next device or EOL resistor
- [3] To next device, BPS, or EOL resistor

DIP switch settings for this application

Each BPS DIP switch can be set this way for the application to work correctly. If other BPS options are required, refer to "Setting the DIP switches" for more information.

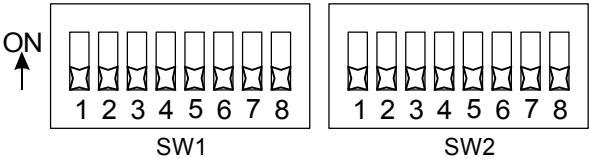

Conventional visible and audible circuit notification

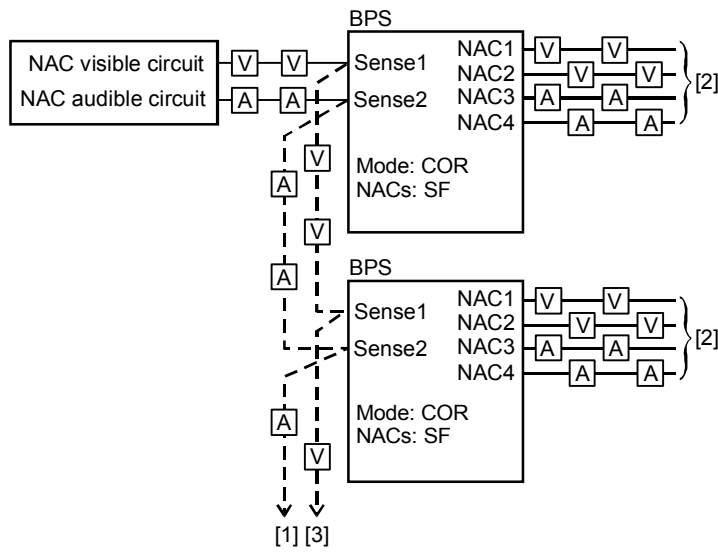

Notes

- [1] The maximum number of BPSs that can be connected on a single NAC from sense circuit to sense circuit is limited by available current and wire run length
- [2] To next device or EOL resistor
- [3] To next device, BPS, or EOL resistor

DIP switch settings for this application

Each BPS DIP switch can be set this way for the application to work correctly. If other BPS options are required, refer to "Setting the DIP switches" for more information.

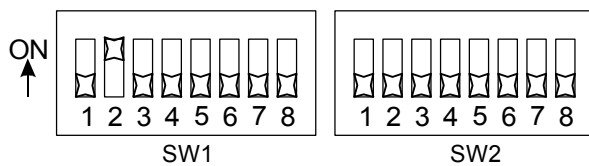

Conventional visible and audible circuit to Genesis notification

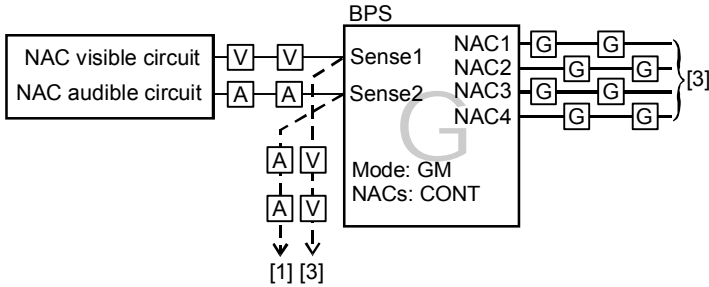

Notes

- [1] The maximum number of BPSs that can be connected on a single NAC from sense circuit to sense circuit is limited by available current and wire run length
- [2] To next device or EOL resistor
- [3] To next device, BPS, or EOL resistor

DIP switch settings for this application

BPS DIP switches can be set this way for the application to work correctly. Refer to "Setting the DIP switches" for other options.

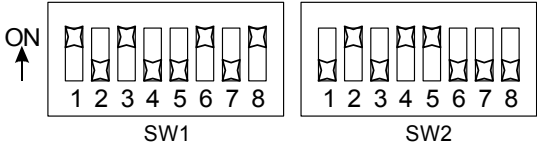

Conventional audible or visible circuit to Genesis notification

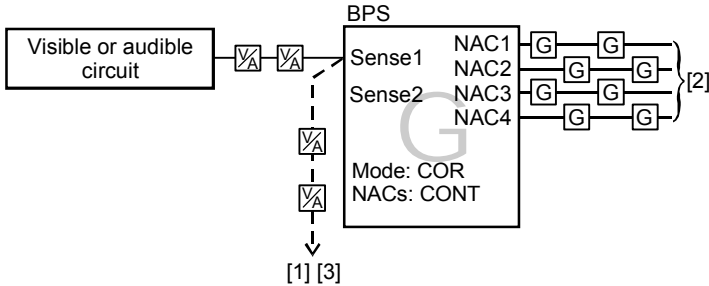

Notes

- [1] The maximum number of BPSs that can be connected on a single NAC from sense circuit to sense circuit is limited by available current and wire run length
- [2] To next device or EOL resistor
- [3] To next device, BPS, or EOL resistor

DIP switch settings for this application

BPS DIP switches can be set this way for the application to work correctly. Refer to “Setting the DIP switches” for other options.

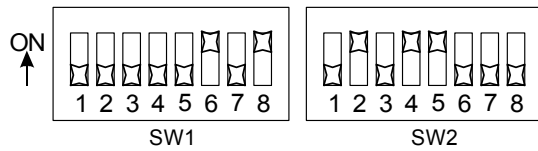

Genesis visible circuit and conventional audible circuit to Genesis notification

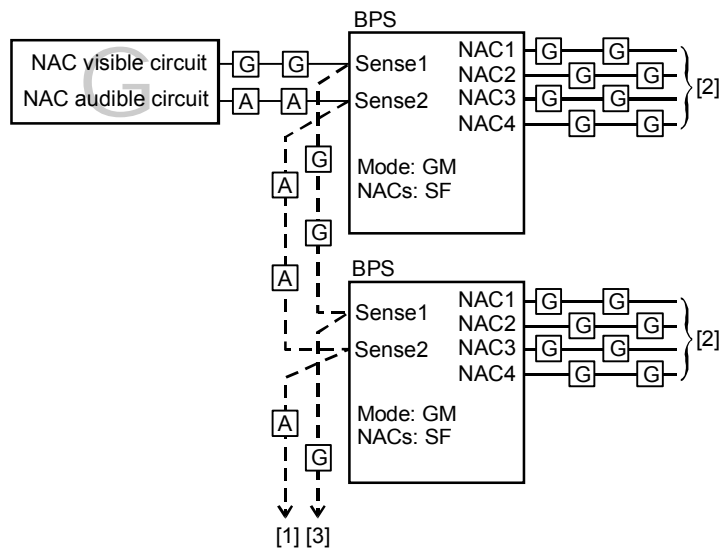

Notes

- [1] The maximum number of BPSs that can be connected on a single NAC from sense circuit to sense circuit is limited by available current and wire run length
- [2] To next device or EOL resistor
- [3] To next device, BPS, or EOL resistor

DIP switch settings for this application

BPS DIP switches can be set this way for the application to work correctly. Refer to “Setting the DIP switches” for other options.

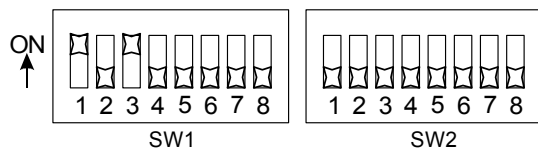

Conventional split mode circuit with fault tolerance notification

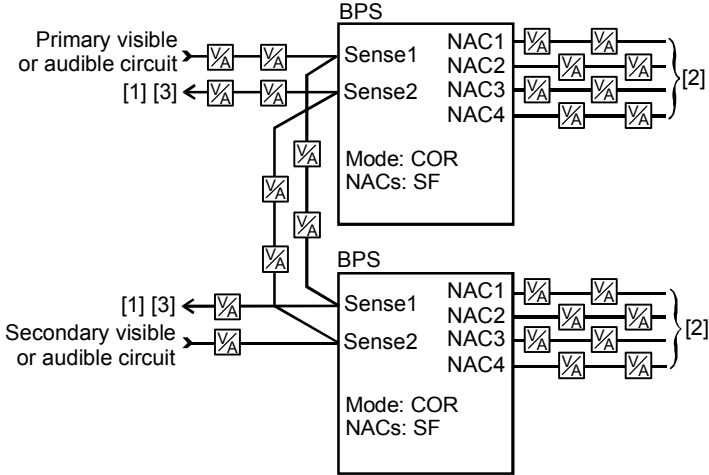

Notes

- [1] The maximum number of BPSs that can be connected on a single NAC from sense circuit to sense circuit is limited by available current and wire run length
- [2] To next device or EOL resistor
- [3] To next device, BPS, or EOL resistor
- 4. Fault tolerance can be increased by using Class A wiring

DIP switch settings for this application

BPS DIP switches can be set this way for the application to work correctly. Refer to "Setting the DIP switches" for other options.

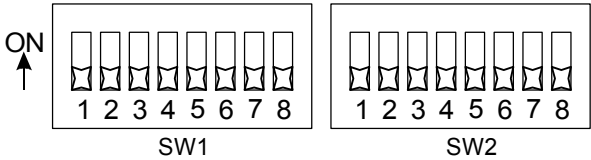

Genesis split mode circuit with fault tolerance notification

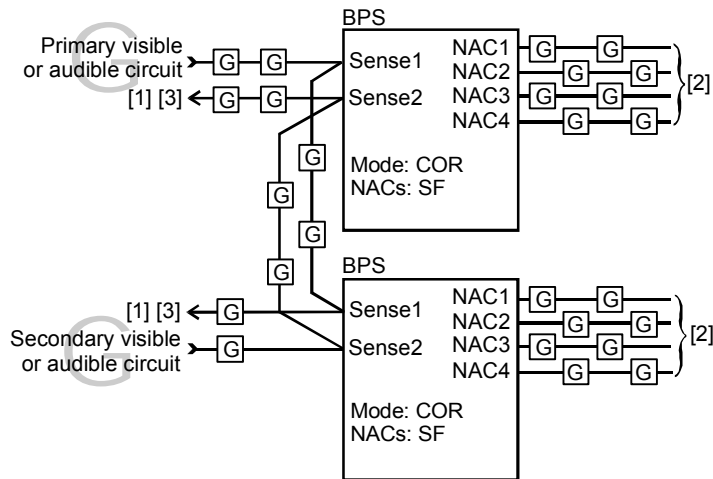

Notes

- [1] The maximum number of BPSs that can be connected on a single NAC from sense circuit to sense circuit is limited by available current and wire run length
- [2] To next device or EOL resistor
- [3] To next device, BPS, or EOL resistor
- 4. Fault tolerance can be increased by using Class A wiring

DIP switch settings for this application

BPS DIP switches can be set this way for the application to work correctly. Refer to “Setting the DIP switches” for other options.

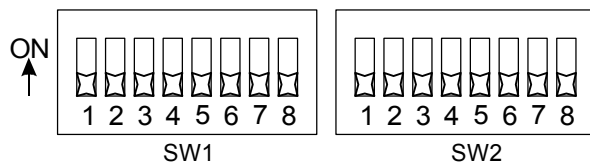

CDR-3 Coder to Genesis notification

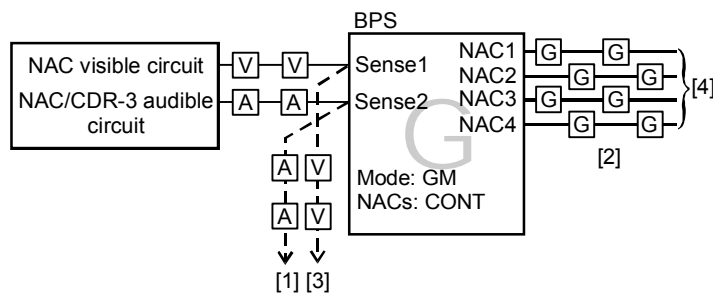

Notes

- [1] To next device, BPS, or EOL resistor
- [2] Cut jumper J1 on the Horn/Strobe to let the horn follow the coder signals
- [3] The maximum number of BPSs that can be connected on a single NAC from sense circuit to sense circuit is limited by available current and wire run length
- [4] To next device or EOL resistor

DIP switch settings for this application

BPS DIP switches can be set this way for the application to work correctly. Refer to "Setting the DIP switches" for other options.

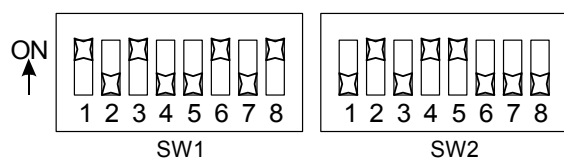

CDR-3 Coder to conventional notification

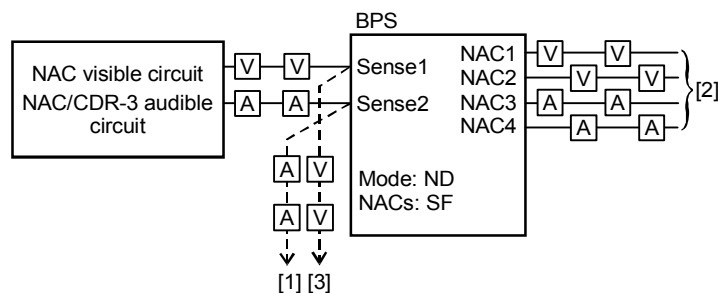

Notes

- [1] The maximum number of BPSs that can be connected on a single NAC from sense circuit to sense circuit is limited by available current and wire run length
- [2] To next device or EOL resistor
- [3] To next device, BPS, or EOL resistor

DIP switch settings for this application

BPS DIP switches can be set this way for the application to work correctly. Refer to "Setting the DIP switches" for other options.

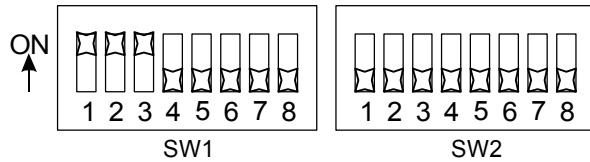

CDR-3 Coder to Genesis visibles and conventional audibles

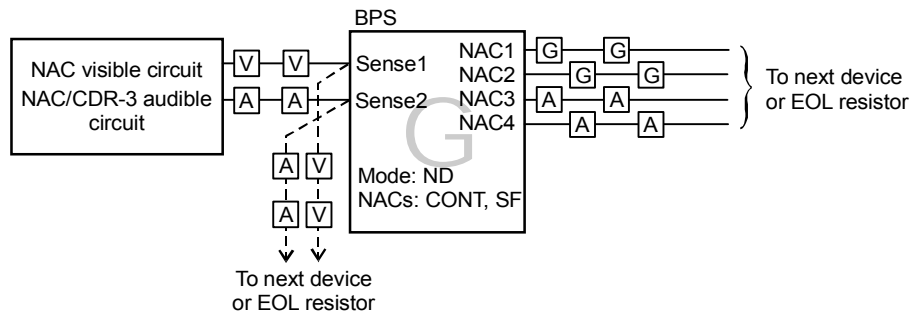

DIP switch settings for this application

BPS DIP switches can be set this way for the application to work correctly. Refer to “Setting the DIP switches” for other options.

NAC1 and NAC2 are configured for continuous mode. NAC3 and NAC4 are configured for sense follow mode. SW2-5 is set to generate a sync pulse on the continuous circuits

BPS

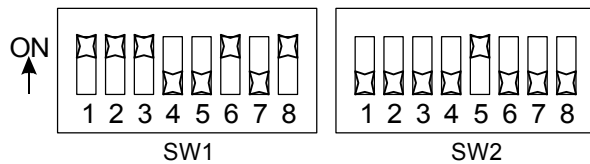

Security

In this application, 24 VDC is converted to 12 VDC for use with security devices.

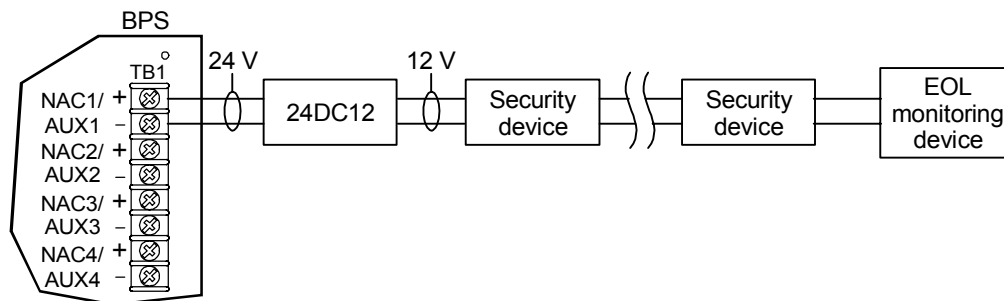

Note: NAC1 must be set for auxiliary. Any of the BPS NACs can be used in auxiliary mode for 12-volt security applications.

DIP switch settings for this application

BPS DIP switches can be set this way for the application to work correctly. Refer to "Setting the DIP switches" for other options.

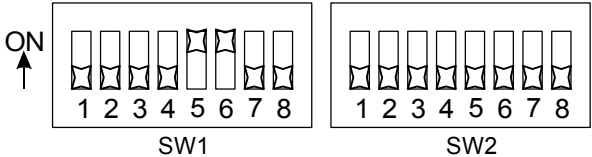

Access control power supply

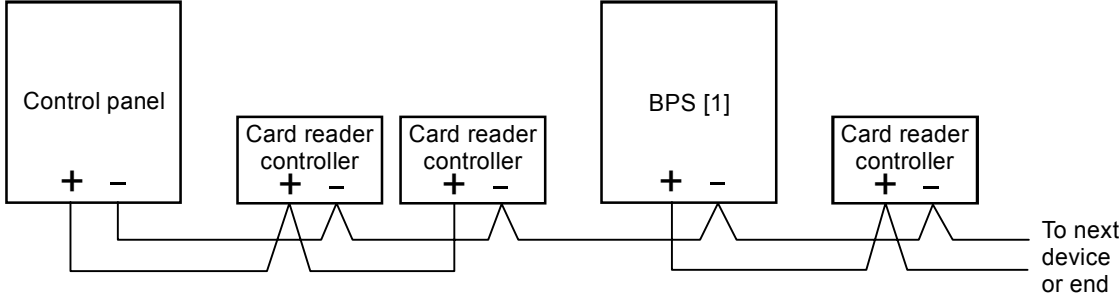

[1] Disable the BPS's ground fault jumper (JP3)

